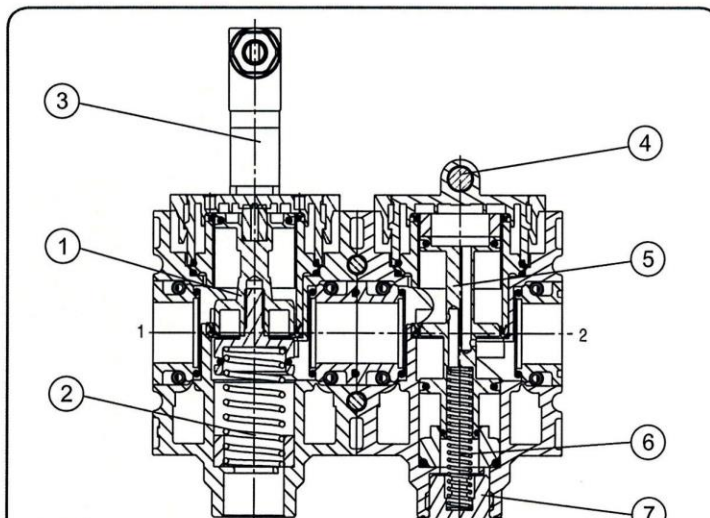

Filling unit »FUTURA« Series

Art. No. 100319 + 100320 - Type No. FU 953 + FU 954
 Art. No. 156622 + 156623 - Type No. FU 953-AC + FU 954-AC
 Art. No. 156628 + 156629 - Type No. FU 957-115V + FU 958-115V
 Art. No. 100325 + 100326 - Type No. FU 957 + FU 958

item	type	FU 953, FU 953-AC FU 957-115V, FU 957	FU 954, FU 954-AC FU 958-115V, FU 958
port size		G 3/8	G 1/2
description		poppet valve	
mounting		arbitrary	
medium		compressed air, neutral gases	
mediums- and ambient temperature		max. 50 °C	
supply pressure		Pe min. 2,5 bar Pe max. 10 bar	
voltage		24 V= ; 24V / 50Hz ; 115V / 50Hz ; 230V / 50Hz	
relative switch-on duration		100 %	
power		1 - 2,5 W with DC 3 VA with AC 50 Hz	
protection class		IP65 according to DIN 40050	
electrical connection		socket coupling EN 175301-803, form C / ISO 15217 poles 2+PE (included in scope of delivery)	
fixing		mounting bracket, wall mounting	
weight		0,920 kg	

parts

no.	designation	material	order-no.
1	valve plunger	brass - NBR	---
2	spring	stainless steel	---
3	pilot valve 24 V incl. socket coupling		
4	regulation spindle	brass - POM	---
5	valve plunger	brass - NBR	---
6	spring	stainless steel	---
7	blanking plug	brass	---

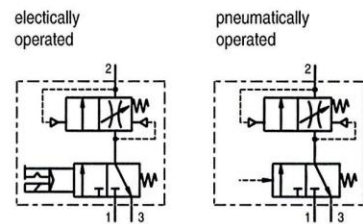

series 2

application information

- switch on and off by 3/2-in line control
- generates a slow pressure build-up in pneumatic systems, avoids a sudden drop in pressure

Filling unit »FUTURA« Series

Art. No. 100319 + 100320 - Type No. FU 953 + FU 954
 Art. No. 156622 + 156623 - Type No. FU 953-AC + FU 954-AC
 Art. No. 156628 + 156629 - Type No. FU 957-115V + FU 958-115V
 Art. No. 100325 + 100326 - Type No. FU 957 + FU 958



dimensions (mm)

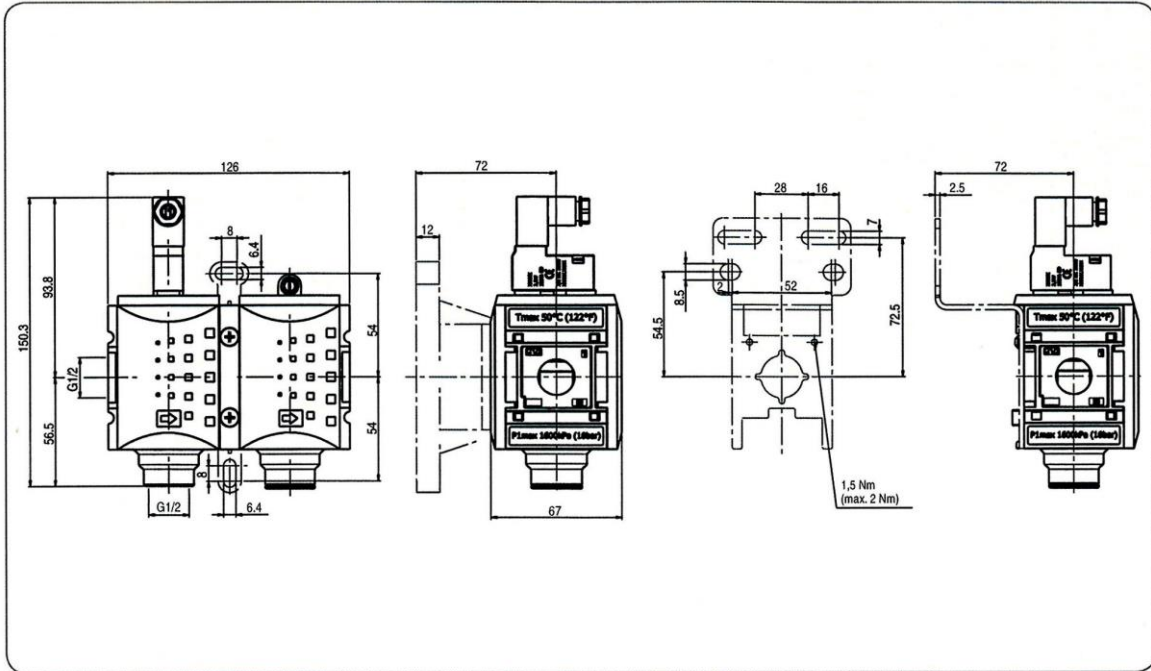

flow characteristic

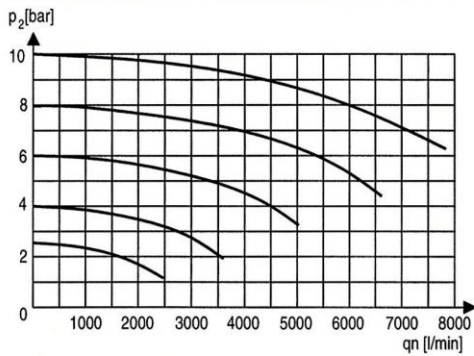

accessories 2

